



DESCRIPTION

- TMP-Series is a temperature controller or Process Digital display with 7-Segment 4 digits
- Universal input. Thermocouple, PT100, 4-20 mA, 0- 10 YDC
- ON/ OFF, P, PD, PID Auto Tuning Control
- Relay output, SSR 0- 10 VDC, 4 -20 mA, 0 -10 VDC
- RS-48S Communication MODBUS RTU Protocol
- Auto Tuning for Auto PID
- Baragraph shows% Output
- Check function Heater break
- Can be selected for both heating and cooling

OPERATION

The TMP-Series is a temperature and process controller that universal input Thermocouple, PT100, 4-20 mA and 0- 10YDC inputs. Thermocouple and PT100 can select Type K,J, R, T, N, S, PT100 and 0-100 mV by pressing the keypad switch can control the whole system is Heating is output ON when the value is lower than Set point or Cooling system is output ON when the measured value is higher than setpoint. Both the ON/ OFF, P, PD and PIO. TheTMP -Series can manually find the PIO by pressing the button. Auto Tuning The system automatically learns the system and PID settings, thus ensuring system stability. In addition, the ON / OFF control can also set the Hysterisis to 0-100% Full Scale. To set the ON and OFF values

The TMP-Series can choose from two output types: Output 1 acts as Heating and Output. 2 acts as Cooling by referencing the same setpoint for more controllable inputs such as Output. 1 Heater Control for Heating and Output 2 Fan Control For cooling exceptTMP-48 (48x48 mm.) No Output 2

Heater Break is a function Check Heater is absent, there will be a CT on the Heater's wires to measure the current in the absence of current flow, indicating that the Heater is inactive

DIMENSION

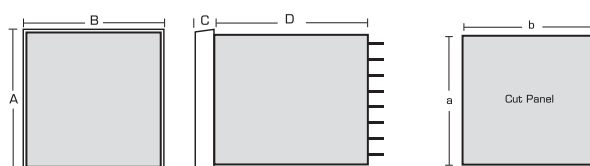

Type	A	B	C	D	a	b
TMP-48	48	48	8	80	45	45
TMP-94	48	96	11	80	45	92
TMP-72	72	72	11	80	68	68
TMP-95	96	48	11	80	92	45
TMP-96	96	96	11	80	92	92

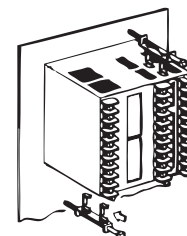

TECHNICAL SPECIFICATION

Power Supply		100-250VAC
		10-24 VAC/VDC
Power Consumption		3 VA
Display	Process Value (PV)	7-Segment 0.56 Inch 4 Digit
	Setting Value (SV)	7-Segment 0.39 Inch 4 Digit
	Output & Alarm	9 LED
Input	Thermocouple	K, J, R, T, N, S, E
	RTD	PT100
	DC Current	4-20 mA
	DC Voltage	0-10 VDC , 0-100 mV
	Accuracy	± 0.25 % FSR @ 25 °C
	Sampling Time	0.5 Sec
Output	Relay	5 A, 250 V, SPDT
	Alarm Relay	3 A, 250 V, SPST
	SSD Driver	0-10 VDC Minimum 600Ω
	Voltage	0-10 VDC Minimum 1 KΩ
	Current	4-20 mA. Maximum 500Ω
Function Control	PID	ON/OFF
	Heating/Cooling	ON/OFF
	Cycle Time	1 - 120 Sec.
	Hysteresis	0 - 100 Fullscale
	Heater Break	1- 30A AC
Communication	Protocol	MODBUS RTU
	Baud Rate	1200, 2400, 4800, 9600, 19200 38400, 57600
	Parity	None, Even, Odd
	Data Bit	8 bit
	Stop Bit	1, 2
	Support Device Node	127
Ambient Operation	Temperature	-20 °C to 60 °C
	Humidity	<85% RH Non-Condensing
Ambient Storage	Temperature	-20 °C to 60 °C
	Humidity	<85% RH Non-Condensing
Protection Degree	Front Protection Rating	IP52
	Case Protection Rating	IP30
Installation		Panel Mountng
Material		ABS-V0
Size/Weight		Dimension Table.

OPERATION GRAPH

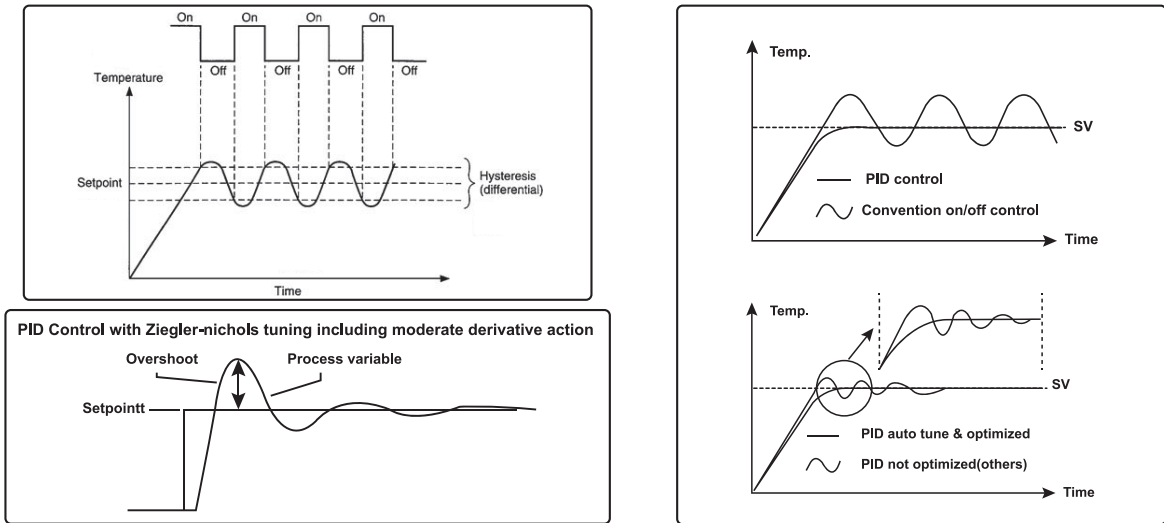

ALARM FUNCTION

1. Deviation High Low Band Alarm

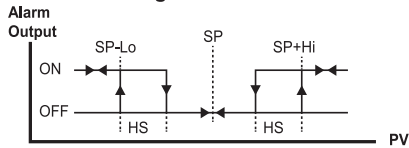

5. Absolute value High Low Band Alarm

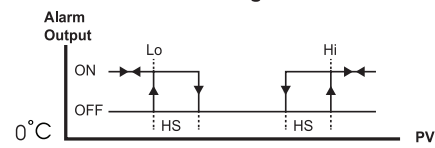

2. Deviation High Alarm

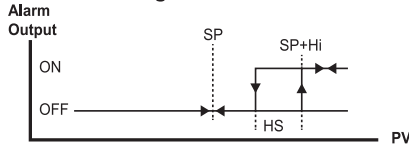

6. Absolute value High Alarm

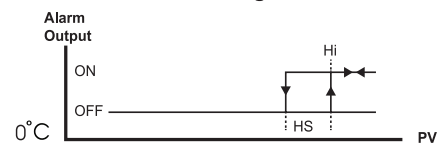

3. Deviation Low Alarm

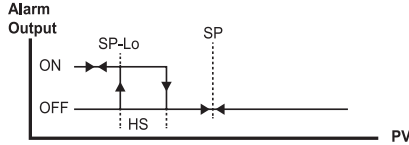

7. Absolute value Low Alarm

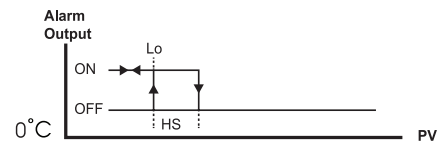

4. Deviation High Low Range Alarm

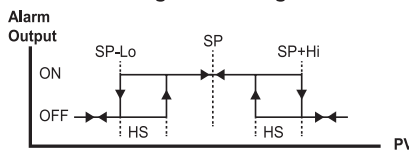

8. Absolute value High Low Range Alarm

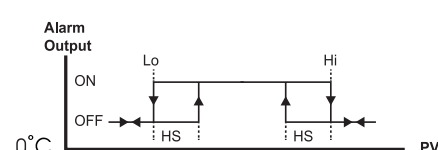

WIRING DIAGRAM FOR HEATER BREAK

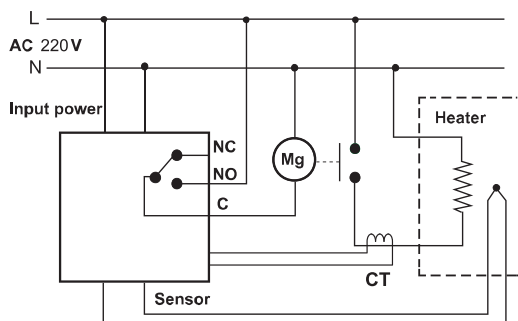

Current Transformer
Maximum 30 A.

INPUT TABLE

Select input sensors and setting range		
Input Type	Setting Range / Display Range	
	Non-decimal point	Decimal point
Thermocouple Type K	-200 ~1372 °C	-199.9~999.9 °C
	-328~2501 °F	-199.9~999.9 °F
Thermocouple Type J	-200 ~1200 °C	-199.9~999.9 °C
	-328~2192 °F	-199.9~999.9 °F
Thermocouple Type R	-50 ~1768 °C	-
	-58~3214 °F	-
Thermocouple Type T	-200~400 °C	-199.9~400.0 °C
	-328~752 °F	-199.9~752.0 °F
Thermocouple Type N	-200 ~1300 °C	-199.9~999.9 °C
	-328~2372 °F	-199.9~999.9 °F
Thermocouple Type S	-50~1768 °C	-
	-58~3214 °F	-
Thermocouple Type E	-200 ~1000 °C	-199.9~999.9 °C
	-328 ~1832 °F	-199.9~999.9 °F
DC 0-100 mV	-1999 ~9999	-199.9~999.9
		-19.99~99.99
		-1.999~9.999
Pt100	-200~850 °C	-199.9~850.0 °C
		-328~1526 °F
DC 4-20mA	-1999 ~9999	-199.9~999.9
		-19.99~99.99
		-1.999~9.999
DC 0-10V	-1999 ~9999	-199.9~999.9
		-19.99~99.99
		-1.999~9.999

WIRING DIAGRAM

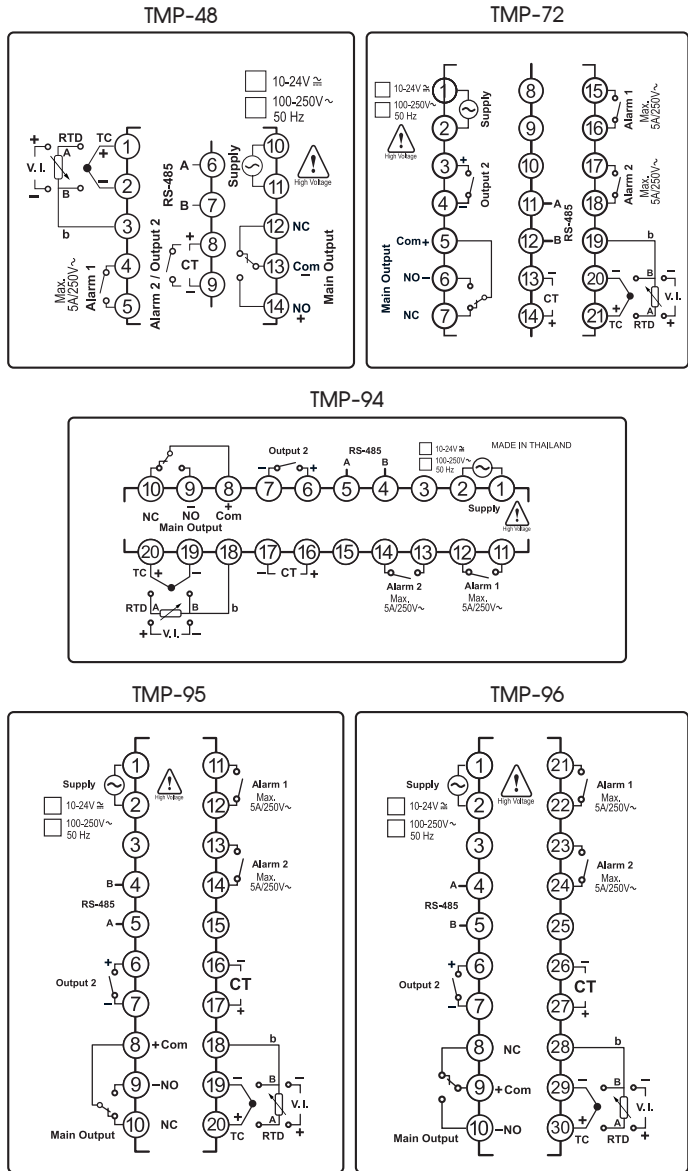

ORDERING CODE

TMP - [SIZE] - [OUTPUT 1] - [OUTPUT 2] - A [OPTION] - [POWER SUPPLY]

SIZE		OUTPUT 1		OUTPUT 2		OPTION		POWER SUPPLY	
48	48 x 48 mm.	R	Relay Contact	N	None	B*	Alarm 2	NONE	100-250 VAC
94	48 x 96 mm.	P	SSR Drive 12 VDC	R	Relay Contact	M	RS-485	D	10-30 VAC/VDC
72	72 x 72 mm.	V	0-10 VDC	P	SSR Drive 12 VDC	H*	Heater Break*		
95	96 x 48 mm.	I	4-20mA	V	0-10 VDC				
96	96 x 96 mm.			I	4-20mA				

* ในรุ่น TMP-48 หากมี Output 2 จะไม่สามารถเลือก Option B, H ได้